



Techfilter System Protection Unit

The Techfilter System Protection Unit provides protection against the intrusion of roots into subsurface drip irrigation systems, for periods up to two years or 200 hours of operation. As water passes through its cartridge of Trifluralin-impregnated discs, minute quantities (parts per billion) of the chemical, are released into the irrigation system.

Features and Benefits:

- Trifluralin chemical is delivered evenly for up to two years throughout the system whenever water is flowing, providing constant protection against root intrusion into drippers.
- Replacement cartridges are available to save the cost of replacing the complete unit.
- Trifluralin cartridges are supplied in a sealed package to optimise shelf life and reduce risk of contamination.
- Trifluralin is classified as a Schedule 5 poison that requires caution during handling. Techfilter cartridges are easily installed and replaced without operator skin contact.

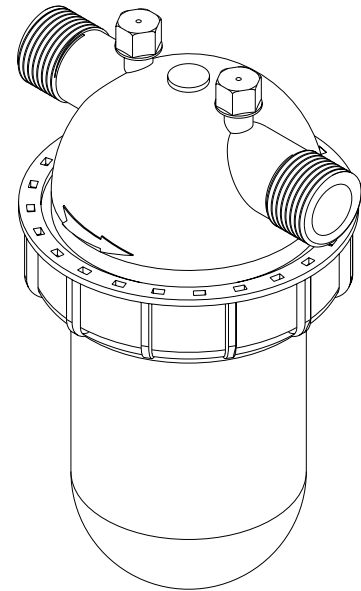

Techfilter Treatment Capacity							
SullDrip System Design Flow Rate (Metres / Techfilter)		13mm ID x 2Lph		13mm ID x 2Lph PC		13mm ID x 4Lph PC	
		30cm spacing		30cm spacing	60cm spacing	30cm spacing	100cm spacing
Min	700Lph	105m	105m	210m	53m	175m	
Max	5,000Lph	750m	750m	1,500m	375m	1,250m	

Techfilter System Protection Unit					
Description	EAN Number	PPI Code	Ord Qty	Ctn Qty	
1" BSP Male	9314212 078919	MT/ATECHF100	1	-	

Handling Instructions

CAUTION: POISON S5. Cartridge contains Trifluralin. Keep out of the reach of children. Rubber gloves and safety goggles must be worn when handling Techfilter cartridges. It is recommended that face shields, coveralls and impervious boots or shoes be worn. Avoid contact with skin and inhalation of vapour.

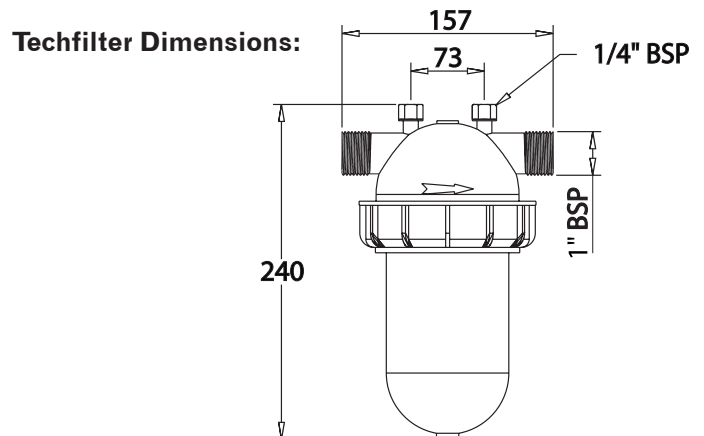

AUSTRALIA – PPI Corporation Pty Ltd (ABN 79 010 656 005)
QLD Sales Office Ph: (07) 3865 2300 Fax: (07) 3857 0058
Townsville Sales Office Ph: (07) 4779 7322 Fax: (07) 4779 2509
NSW Sales Office Ph: (02) 8706 2400 Fax: (02) 8706 2499
VIC Sales Office Ph: (03) 9791 3700 Fax: (03) 9791 3900
SA Sales Office Ph: (08) 8447 2611 Fax: (08) 8447 8117
TAS Sales Office Ph: (03) 6248 5933 Fax: (03) 6248 5988
WA Sales Office Ph: (08) 9212 3200 Fax: (08) 9355 0675
NT Agent Territory Hardware Ph: (08) 8947 1250 Fax: (08) 8984 4461

EXPORT ENQUIRIES Ph: +61 7 3865 3699 Fax: +61 7 3857 0058

NEW ZEALAND – PPI Corporation (NZ) Limited
 Christchurch Ph: (03) 313 7956 Fax: (03) 313 5551

EMAIL: sales@ppi.com.au
WEB: www.ppi.com.au

Date: 5th December 2006
Code: ZM/LT3MTTSPU