

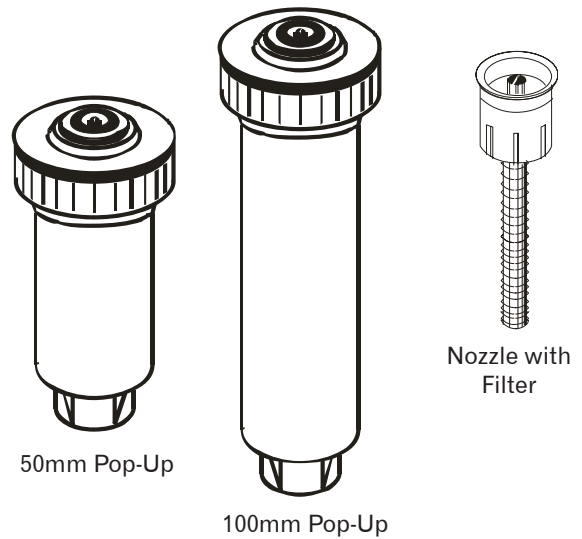

Spray Head Pop-Ups & Shrub Adaptors

Features and Benefits:

- 50mm Pop-Ups suitable for most small to medium lawns
- 100mm Pop-Ups for applications that require extra height
- Shrub Adaptors for garden beds
- Ratchet mechanism to rotate spray direction
- Adjustable throw (brass screw in nozzle)
- Matched flow rates
- Built-in filter – easy to remove
- Large body diameter for more stability in loose soils
- Interchangeable nozzles
- Special wiper seal
- Corrosion proof and UV resistant







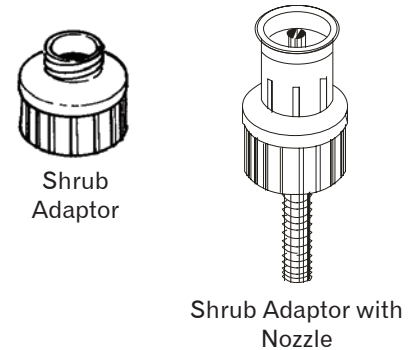

Specifications:

	50mm Pop-Up	100mm Pop-Up
Operating Range	100 – 200kPa	100 – 200kPa
Optimum Working pressure	175kPa	175kPa
Pop-Up Height	55mm	104mm
Body Height	98mm	148mm
Inlet Size	½" BSP Female	½" BSP Female
Warranty	12 Months	12 Months



Performance @ 175kPa

Pattern	Flow (Lpm)	Radius (m)
Adjustable Arc 25° – 360° 	8.5 (@ Full Circle)	3.5
Quarter Circle 90° 	3.0	3.5
Half Circle 180° 	5.0	3.5
Three Quarter Circle 270° 	7.5	3.5
Full Circle 360° 	10.0	3.5
Centre Strip 	5.0	1.1 x 8.0
Narrow Strip 	5.0	1.1 x 8.0

AUSTRALIA – PPI Corporation Pty Ltd (ABN 79 010 656 005)
QLD Sales Office Ph: (07) 3865 2300 Fax: (07) 3857 0058
Townsville Sales Office Ph: (07) 4779 7322 Fax: (07) 4779 2509
NSW Sales Office Ph: (02) 8706 2400 Fax: (02) 8706 2499
VIC Sales Office Ph: (03) 9791 3700 Fax: (03) 9791 3900
SA Sales Office Ph: (08) 8447 2611 Fax: (08) 8447 8117
TAS Sales Office Ph: (03) 6248 5933 Fax: (03) 6248 5988
WA Sales Office Ph: (08) 9212 3200 Fax: (08) 9212 3200
NT Agent Territory Hardware Ph: (08) 8947 1250 Fax: (08) 8984 4461

EXPORT ENQUIRIES Ph: +61 7 3865 3699 Fax: +61 7 3857 0058

NEW ZEALAND – PPI Corporation (NZ) Limited
Christchurch Ph: (03) 313 7956 Fax: (03) 313 5551

EMAIL: sales@ppi.com.au
WEB: www.ppi.com.au

Date: 4th December 2006
Code: ZM/LT3MT2PUS