



Solenoid Valve Maintenance

Introduction

Three quarters of all automatic irrigation problems are attributed to solenoid valves. An understanding of their operation is the first important step in being able to trouble shoot problems and successfully maintain an entire system.

Operating Principle

The main operating principle behind solenoid valves is hydraulics and not electrical as the name suggests. Low voltage electricity is only used to actuate the valves. It is hydraulics that operate the valve and ensure a leak proof shut off.

The Solenoid

The electrical portion of the valve is the solenoid assembly. It controls the flow of water between the upstream and downstream side of the valve. When current is applied to the solenoid the electromagnetic forces lift the plunger and when the current is removed a spring returns the plunger to its seat.

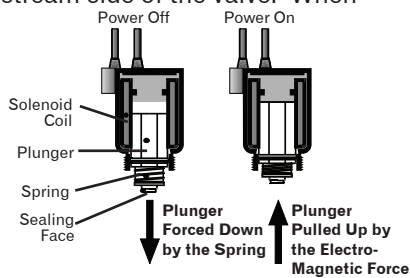

Valve – Shut Off

When there is no current flowing through the solenoid the plunger seals on its seat stopping the flow of water. Water flows into the valve and then into the upper chamber through a port in the valve's diaphragm. The pressure above the diaphragm is the same as the pressure upstream of the valve, but the area on top of the diaphragm is greater than the area of the valve opening, so there is a mechanical force downwards which seals the diaphragm. The valve is now closed.

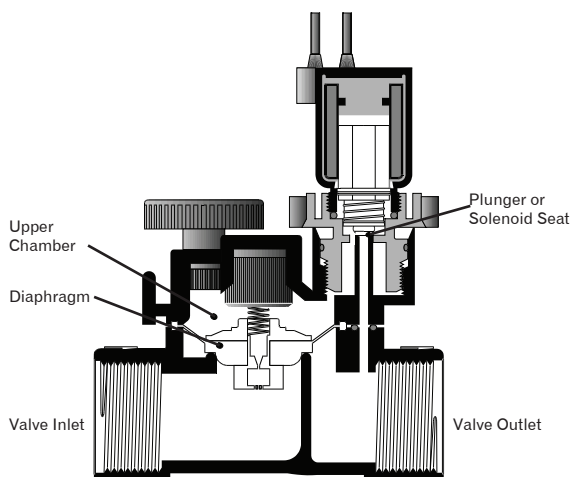

Valve – Opening

When the solenoid is activated the plunger is raised and water flows through the bleed passage resulting in a pressure drop above the diaphragm. The pressure on top of the diaphragm is now lower than below and the diaphragm is forced up allowing the water to flow through the valve.

The valve will remain open so long as the solenoid is energised.

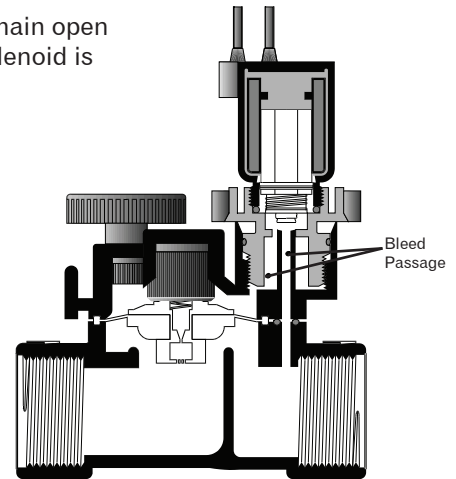

Manual Operation

Solenoid valves can be operated manually. This is done by a manual bleed screw which operates the same way as the plunger in the solenoid. The better quality valves have an "internal bleed", so that the bleed water flows into the downstream pipe and not outside of the valve to flood the ground or valve box. Remember that the bleed stream runs continuously while the valve is open. The popular methods of Manual Bleed are ; screwing the solenoid or its housing to lift the plunger, using a cam to raise the plunger independently of the solenoid, a separate bleed screw which operates on a different seat than the plunger.

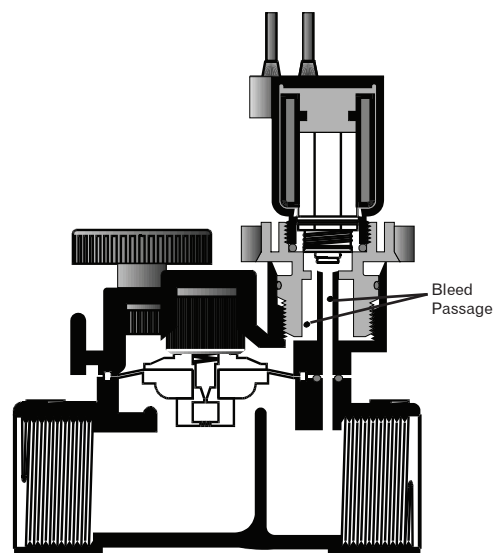

Flow Control

Most valves have a flow control option. Flow control is achieved by limiting the movement of the diaphragm by a screw knob. When the screw is wound down the diaphragm's movement is limited and the flow is reduced. When the screw is wound up the diaphragm has full movement and maximum flow is allowed.

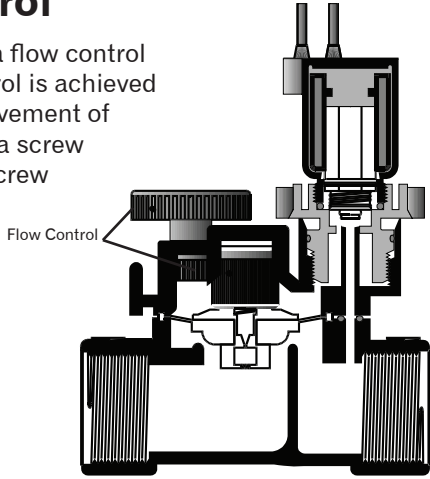

Valve Maintenance

Valves can only have two problems. They will either not open or they will not close.

In any trouble shooting it is best to isolate the simple possibilities first.

The valve will not open:

1. Flow Control is open.

Check to see if the flow control stem is opened by turning it anticlockwise. This is the most common reason a valve will not open in new installations but it should not be a problem with a valve that has been working for a period of time unless it has been tampered with.

2. Operate Manually

If the valve operates manually then there is an electrical problem. If it does not operate manually then there is a blockage in the valve. It will need to be disassembled in accordance with the manufacturers instructions. Large blockages will be obvious. The not so obvious areas will be the small passage through the centre of the diaphragm and the bleed passage. Be particularly careful when cleaning the diaphragm. It's a personal decision, but consideration needs to be given to replacing any diaphragm that is greater than 5 years old as servicing can damage the sealing faces.

3. Solenoid check

Test the solenoid using a multimeter. (It does not need to be an expensive multimeter. A \$20 unit is acceptable providing it is well protected when it is not in use.) Read the resistance across the two leads of the solenoid and compare it with the values specified by the manufacturer. Generally a good reading will be between 13 to 25 ohms. If need be, replace the solenoid and re-test the valve.

4. System Power

Using the multimeter check for power at the solenoid by activating the zone in question at the controller. While at the controller test for 24 volts across the zone lead and the common. If there is no power present then the controller is malfunctioning or has not been set correctly. (Some people prefer to check the controller output prior to doing any check at the valve.) If the controller is functioning correctly conduct the same voltage check at the valve. If you still get no voltage then you have a broken wire.

If you don't have a multimeter you can still check the output at the controller by connecting the zone wire from a valve that is working to the faulty zone terminal. If the valve still works the controller is functioning correctly. Similarly at the valve end you can connect a solenoid that is known to work and listen for the click as the station is turned on, however do not connect the solenoid when the station is on as it may short the controller.

Once it has been established that the wire has a break in it check the site for any recent construction, planting or excavations that could have resulted in nicks or cuts in the control wires. Also check all the wire connections especially on the common wire if it is wired from valve to valve. If you can't find the break consider calling in a contractor with a "fault-finder" or hire one yourself.

The valve will not close:

1. Flow Direction

Ensure that the water is flowing in the direction indicated by the arrows marked on the body of the valve. This is the most common reason a valve will not close but it only needs to be considered on new installations.

2. Clean

Dismantle the valve and clean all the ports including the diaphragm. Clean the plunger post thoroughly since the plunger may be lodged open and is not sealing the downstream port. The diaphragm may also be damaged or ruptured or may not be seating correctly. Remove the diaphragm and inspect it closely. Replace the diaphragm if necessary and remember to give consideration to its age.

3. Adjust Flow Control

The water pressure in the supply line may be too low. If this is the case, there will be insufficient pressure above the diaphragm to overcome the pressure of the water travelling through the valve. This can be overcome by adjusting the flow control down until you hear the valve close automatically. By reducing the flow path a partial vacuum is created which aids the lowering of the diaphragm. With the flow control at this position, the valve will now continue to open and close automatically when