

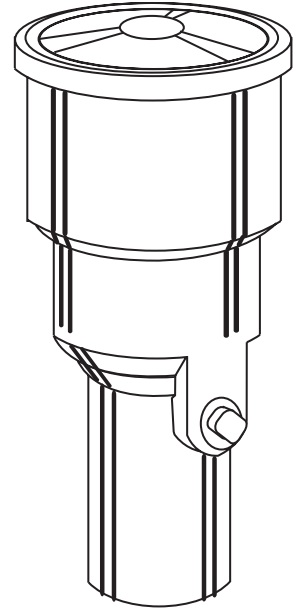

Impact Pop-Up Sprinkler

Features and Benefits:

- Adjustable spray pattern.
- Filter screen protect nozzle and drive from debris.
- Side or bottom entry depending on installation requirements.
- Ideal for most commercial and residential turf irrigation needs.
- Made from UV stabilised material.
- Stainless steel spring ensures positive retraction.
- 12-month warranty.



Specifications:

Operating Pressure:	100 – 300kPa
Optimum Working Pressure:	200kPa
Arc Adjustment:	30° – 360°
Body Height:	230mm
Pop-Up Height:	80mm
Inlet Size:	½" BSP Female

Performance Data:

Pressure (kPa)	Discharge (Lpm)	Diameter (m)
100	5.3	16
150	7.9	19
200	9.6	21
250	11.0	22
300	12.3	23

AUSTRALIA – PPI Corporation Pty Ltd (ABN 79 010 656 005)
QLD Sales Office Ph: (07) 3865 2300 Fax: (07) 3857 0058
Townsville Sales Office Ph: (07) 4779 7322 Fax: (07) 4779 2509
NSW Sales Office Ph: (02) 8706 2400 Fax: (02) 8706 2499
VIC Sales Office Ph: (03) 9791 3700 Fax: (03) 9791 3900
SA Sales Office Ph: (08) 8447 2611 Fax: (08) 8447 8117
TAS Sales Office Ph: (03) 6248 5933 Fax: (03) 6248 5988
WA Sales Office Ph: (08) 9212 3200 Fax: (08) 9355 0675
NT Agent Territory Hardware Ph: (08) 8947 1250 Fax: (08) 8984 4461

EXPORT ENQUIRIES Ph: +61 7 3865 3699 Fax: +61 7 3857 0058

NEW ZEALAND – PPI Corporation (NZ) Limited
Christchurch Ph: (03) 313 7956 Fax: (03) 313 5551

EMAIL: sales@ppi.com.au
WEB: www.ppi.com.au

Date: 25th January 2007
Code: ZM/LT3MTIPUS