

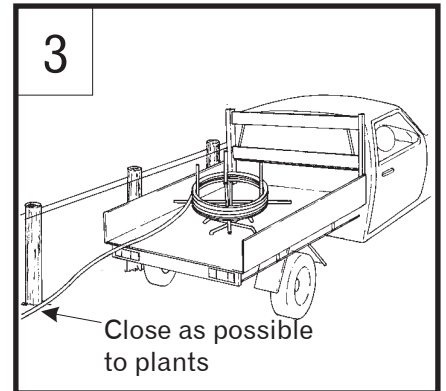

TrellTube™ & TrellDrip™ Installation Instructions

Rolling Out

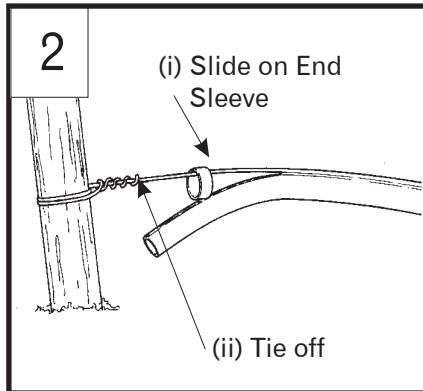
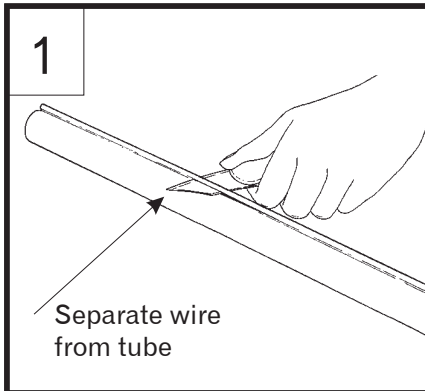

Tying Wire

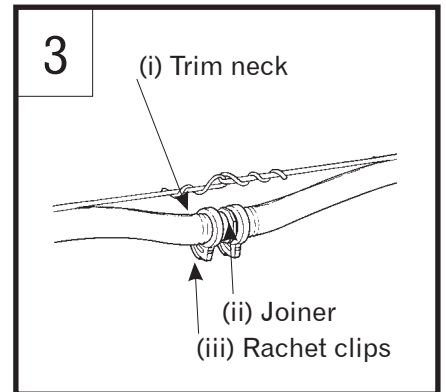
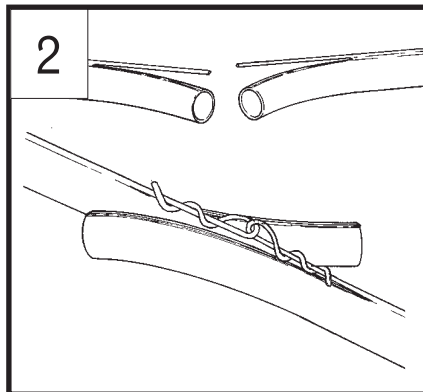
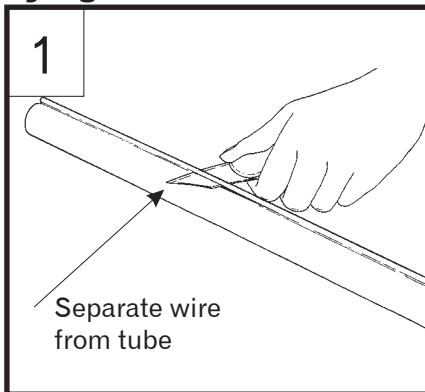

Using a Gripple™ Joiner

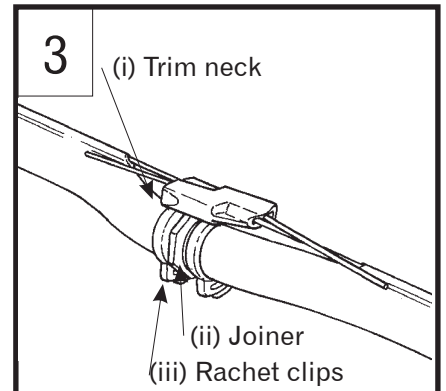
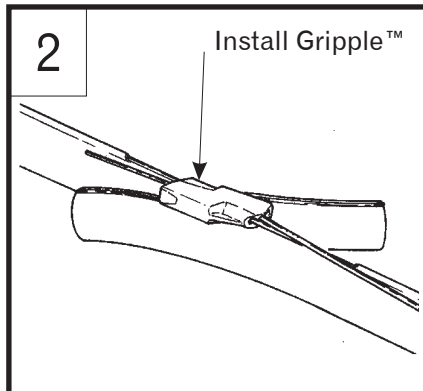
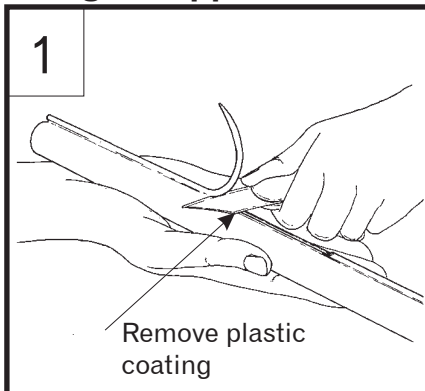

Tensioning Wire

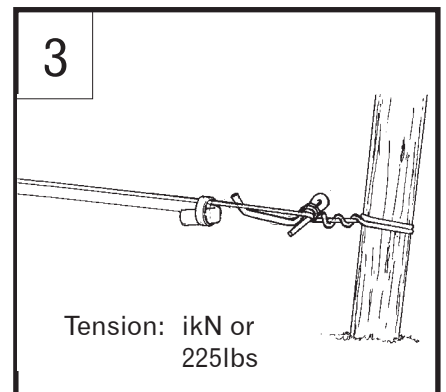
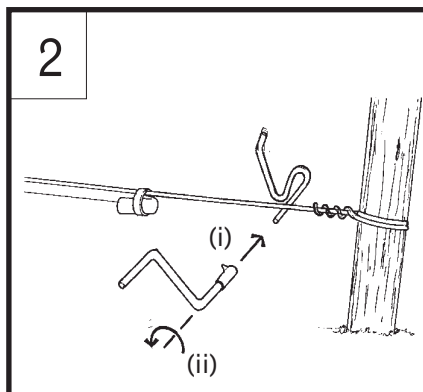
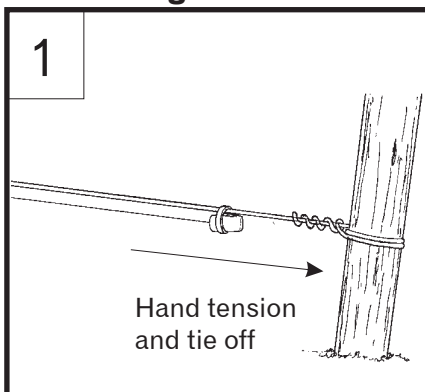

Post Attachment

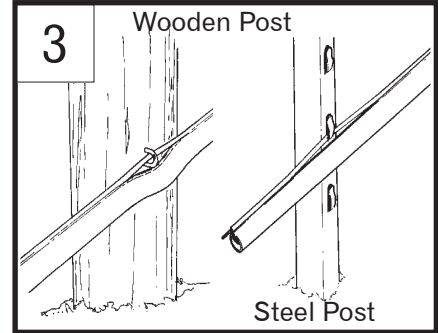
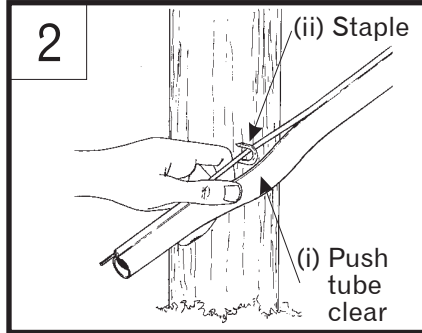
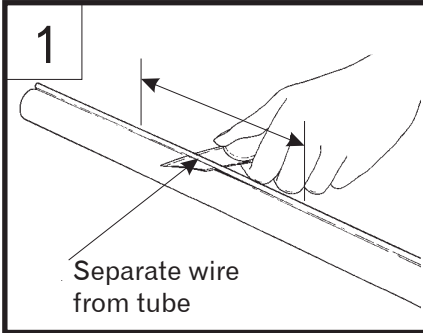

"T" Connection

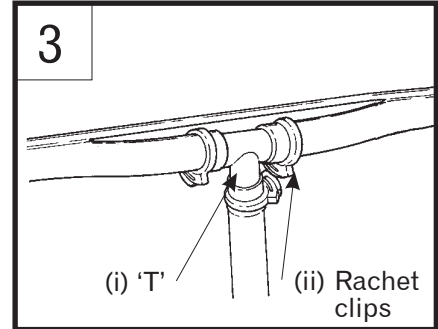
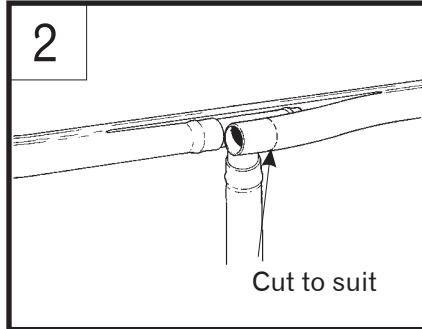
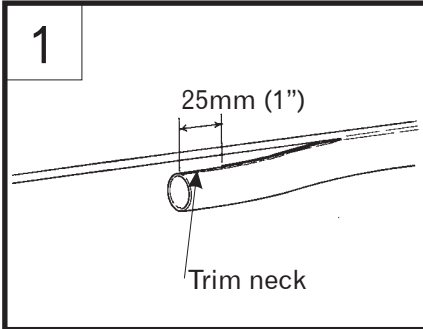

Elbow Connection

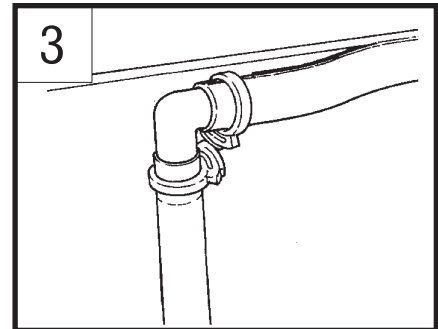
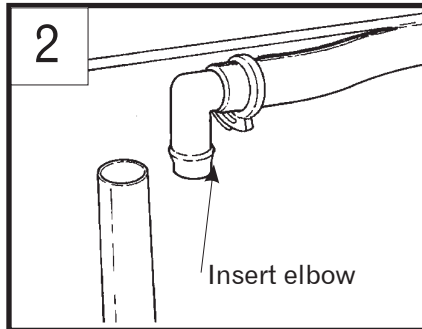
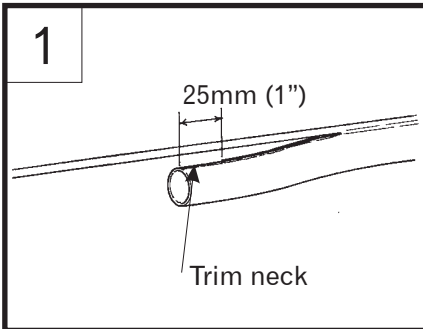

Small Tube Repair

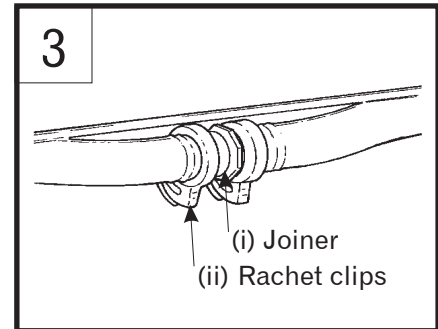
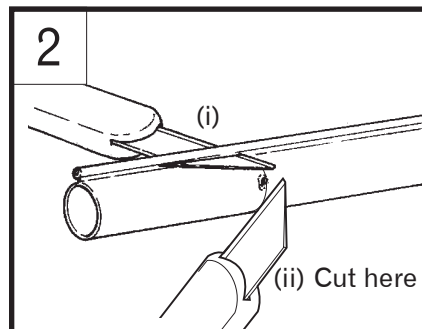
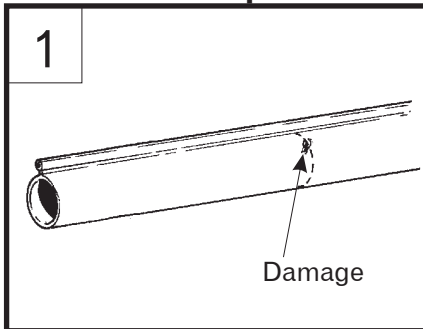

Large Tube Repair

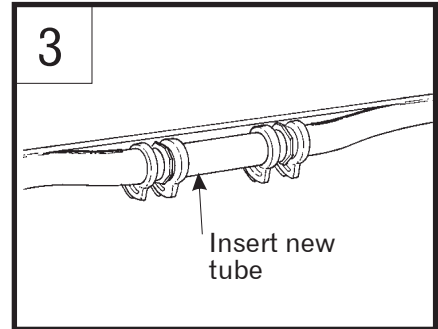
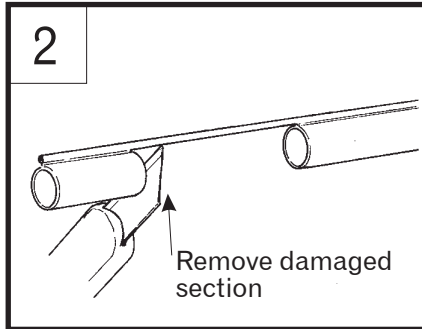
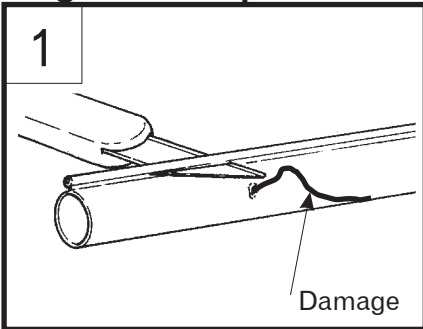

2 of 2

AUSTRALIA - PPI Corporation Pty Ltd (ABN 79 010 656 005)

QLD Sales Office	Ph: (07) 3865 2300	Fax: (07) 3857 0058
Townsville Sales Office	Ph: (07) 4779 7322	Fax: (07) 4779 2509
NSW Sales Office	Ph: (02) 8706 2400	Fax: (02) 9355 0675
VIC Sales Office	Ph: (03) 9791 3700	Fax: (03) 9791 3900
SA Sales Office	Ph: (08) 8447 2611	Fax: (08) 8447 8117
TAS Sales Office	Ph: (03) 6248 5933	Fax: (03) 6248 5988
WA Sales Office	Ph: (08) 9212 3200	Fax: (08) 9355 0675
NT Agent Territory Hardware	Ph: (08) 8947 1250	Fax: (08) 8984 4461

EXPORT ENQUIRIES Ph: +61 7 3865 3699 Fax: +61 7 3857 0058

NEW ZEALAND - PPI Corporation (NZ) Limited
Christchurch Ph: (03) 313 7956 Fax: (03) 313 5551

EMAIL: sales@ppi.com.au
WEB: www.ppi.com.au

Date: 23rd November 2006
Code: ZM/LT2MDTTIS